



Single

Assembly & User Instructions



Take
a stand for
Office Wellbeing
with
Standing Desks



Contents

Single

Use/Liability	3
Parts List/Tools	4
Assembly	5-8
Trouble Shooting	9
Specifications	9
Programming	10-12

Assembly



Make sure no obstacles are in the desk's path.
Make sure the desktop is not touching any walls.
Make sure all cords are appropriate length to
accommodate the change in height.



WARNING

Pinch Point
Keep hands and
fingers clear.



Keep children away from electric height-adjustable desks, control
units and handsets. There is a risk of injury and electric shock.



Keep all electrical components away from liquids.



Do not sit or stand on the desk frame.
Do not crawl or lie under the desk frame.



Do not place any objects taller than 20" underneath the desk.



Do not open any of the components - the Legs, Control Box, or Switch.
There is a danger of electric shock.



This product is designed with a duty cycle of 10%
(2 min. on, 18 min. off).



In the event of a power outage or if the power cord is unplugged, a
manual reset may be necessary - see USE section.



IMPORTANT: You must RESET the desk prior to use.



Use / Liability

This height adjustable desk has electric motors and is designed for use in dry work areas only.

The desk height is adjustable so that it can be positioned at the most ergonomically suitable height.

Any other use is at users risk.

Under no circumstances does the manufacturer accept warranty claims or liability claims for damages caused from improper use or handling of the desk frame.

Please be informed that the anti-collision software is designed for furniture protection, not human protection.

Parts List

Tools



4mm Allen Wrench (included)



Phillips Head Screwdriver
and/or Power Drill



Tape Measure

Parts List

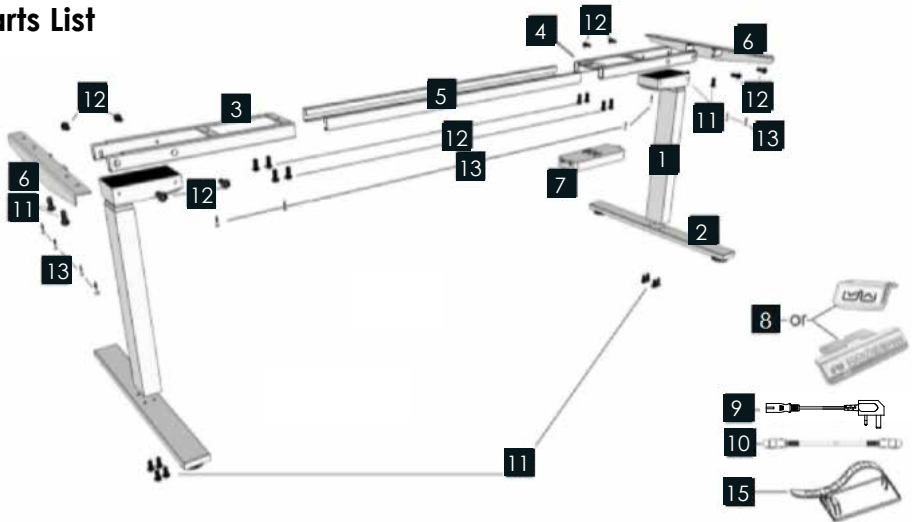

Part	Qty
1 Leg	2
2 Foot	2
3 Frame End-CB	1
4 Frame End	1
5 Centre Rail	2

Part	Qty
6 Side Bracket	2
7 Control Box	1
8 Handset	1
9 Power Cord	1
10 Cable	1

Part	Qty
11 M6x14 Machine Screw	23
12 M6x10 Machine Screw	16
13 M5x20 Wood Screw	11
14 M5x16 Wood Screw	2
15 Cable Clip	10

Assembly

Ensure there are no obstacles in the desk's path, and that the desktop is not touching any walls. Please also ensure that all cords are an appropriate length to accommodate the change in height.



IMPORTANT: You must RESET the desk prior to use.

- 1** Lay out all components and hardware to ensure that you have all items listed on the parts page. Slide the Control Box (part 7) off the Frame End-CB (part 3) and set aside.

Fully separate Frame End (part 4) from Frame End-CB (part 3). You will find the Centre Rail (part 5) inside.

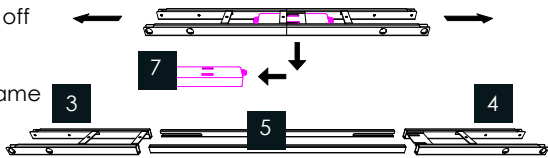

- 2** Place one of the Legs (part 1) into the Frame End-CB (part 3) ensuring that the bar is on "top" in relation to the Leg (part 1).

Line up the holes on the Leg (part 1) with the holes on the Frame End-CB (part 3).

Using the supplied Allen Wrench, insert four (4) M6x10 Machine Screws (part 12) through the holes in the Frame End-CB (part 3), going into the Leg (part 1) and rotate each screw just a few turns. After all four (4) M6x10 Machine Screws (part 12) are inserted, tighten all four (4) screws. Do the same for the other Leg (part 1) and the Frame End (part 4).

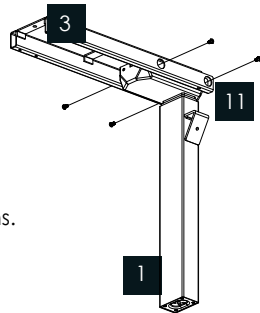

- 3** The Frame End-CB (part 3) should be placed on the side of the desk where you plan to mount the Control Box (part 7) and the Handset (part 8).
- Slide the Side Bracket (part 6) into the Frame End-CB (part 3). Insert two (2) M6x14 Machine Screws (part 11) through the two (2) holes in the bottom of the Frame End (part 3) going into the inserted Side Bracket (part 6). Using the supplied Allen Wrench, rotate each screw just a few turns. After both M6x14 Machine Screws are inserted, tighten both screws.

Do the same for the other frame end/leg assembly.

Assembly

4

Slide the two (2) Centre Rails (part 5) into the two Frame Ends (parts 3 & 4) ensuring: a) the slots in the Centre Rail (part 5) face inward b) the slots in the Centre Rail (part 5) are closer to the top edge when the assembly is upside down (see inset).

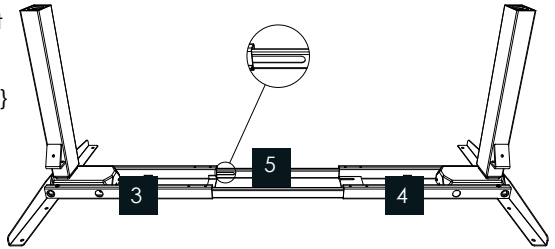

5

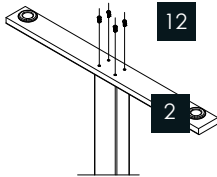

For each leg assembly, attach a Foot (part 2) with four (4) M6x14 Machine Screws (part 11) and tighten in a cross-pattern.

6

Check both sides of the desktop before placing the desk base on the underside of the desktop.

Adjust the width of the desk base to fit the desktop by sliding the two halves outward. We recommend leaving at least 1/2" of the desktop width (on each end) protruding beyond the frame width and centering the side brackets (part 6) before and after.

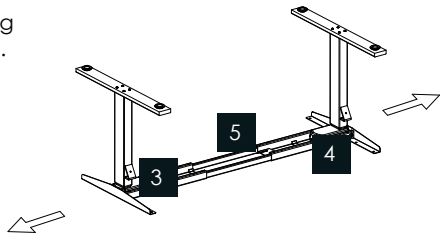

7

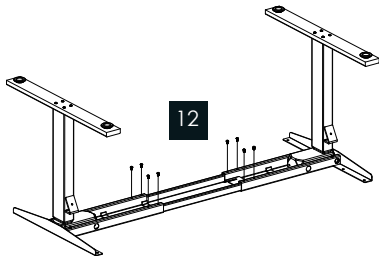

Lock the position of the Centre Rail (part 5) using eight (8) M6x10 Machine Screws (part 12).



Ensure the M6x10 Machine Screws (part 12) contact the Centre Rail (part 5) by sliding the Centre Rail (part 5) as needed.

Assembly

8



Double check that the wood screws are not too long for your desktop and won't puncture the surface when screwed all the way in.

We recommend that you pre-drill any holes needed for fasteners. Never use countersunk screws.



Double check that the desk base is properly positioned on the underside of the desktop.

If using different drilled top attached the desk base to the underside of the desktop using eleven (11) M5 x 20 wood screws (part 13) Please note you will have eleven(11) M6 x 14 machine screws (part 11) spare.

or

If using pre drilled top attach the desk base to the underside of the desktop using eleven(11) M6 x 14 Machine screws (part 11). Please note you will have eleven (11) M5 x 20 Wood screws (part 13) spare.

Attach the Handset (part 8) so the front of the handset is flush with the front desktop edge (or recessed up to 1/8"). The handset may be placed anywhere along the front edge of the desktop, but we recommend placing it towards an end so it prevents interference when seated. Use two (2) M5x16 Wood Screws (part 14) to attach the handset to the desktop.



Do not overtighten screws in this step. Overtightening could cause damage to the components.

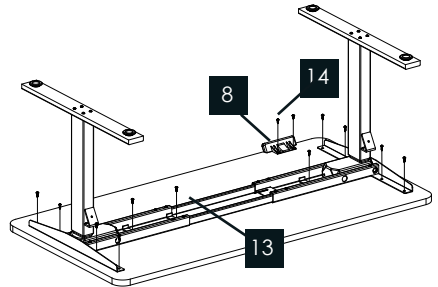

9

Slide the Control Box (part 7) onto the Frame End-CB (part 3).

Connect the cable exiting the Leg (Part 1) that is attached to the Frame End-CB (part 3) directly into the Control Box (part 7).

Connect the Cable (part 10) to the other Leg (part 1) and to the Control Box (part 7).

Connect the Handset (part 8) cable to the Control Box (part 7).

Connect the Power Cord (part 9) to the Control Box (part 7).

Use the adhesive-backed Cable Clips (part 15) to secure the cables so they do not sag.

Please note you wont need extension cable (part 10) if using a small top.

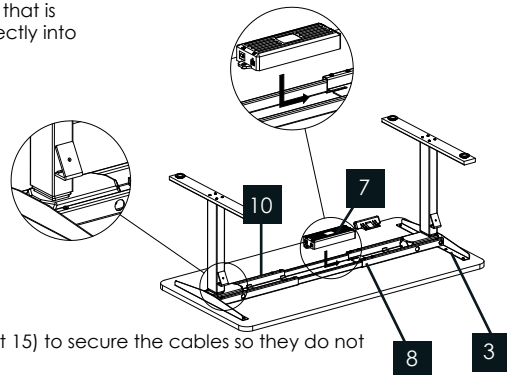

Assembly

- 10 Turn the assembled desk right-side up. With at least two people, grab the DESK BASE (not the desktop) and turn the desk right-side up. Adjust the pre-installed glides on the Feet (part 2) as needed.
-

- 11 Plug the Power Cord (part 9) into a 230v outlet.
-

- 12 **RESET PROCEDURE**
Press and hold the DOWN button on the Handset (part 8) until the desk reaches its lowest height.

Release the DOWN button.

Press and hold the DOWN button again for about 10 seconds.

Release the DOWN button.

Press and hold the DOWN button again until the desk lowers a little bit more, slightly rises and stops.

Release the DOWN button.

Your desk is now ready to use.

The desk base can be adjusted by pressing and holding either the UP or DOWN button until the desired height is reached.

Ensure there are no obstacles in the desk's path, and that the desktop is not touching any walls. Please also ensure that all cords are an appropriate length to accommodate the change in height.



IMPORTANT: You must RESET the desk prior to use.

Trouble Shooting

If your desk is not functioning properly it may need to be reset. Follow the RESET procedure outlined in the USE section.

If your desk has a handset with an LED readout and it displays "RST" (reset), perform the reset procedure outlined in the USE section.

If the LED readout displays an error message (*Er1* - *Er13*) confirm that all wired connections are secure (legs to cables, cables to control box). Then perform the reset procedure outlined in the USE section.

If the error message persists after the reset procedure, contact your seller.

If the height between the legs exceeds 1.5 inches, stop the reset procedure & contact your seller.

If the handset displays "HOT", let the base cool down for 20 minutes.

Specifications

Height Range	595 - 1245 mm (without desktop)
Base Width	1200 - 1800 mm
Travel Speed	40 mm per second (no load)
Distributed Load	125Kg
Duty Cycle	After 2 min. continuous use rest for 18 min to prevent overheating
	Soft start/stop
	Adjustable leveling studs
	3 Memory presets

Programming

1

Resetting the base

When the LED display shows an error code, press the 'DOWN' button for up to 5 seconds until the LED changes to a flashing 'RST'

Press the 'DOWN' button again until the base has lowered and then slightly risen. The base is now ready for use.

2

To set the upper-limit position

Use the 'UP' button to move the base to the desired max height position.

Press the 'M' button and release. Press the 'UP' button and release. The LED display will flash 'S'. Press and hold the 'M' button for about 2 seconds, or until the LED display changes to '999'. The display will automatically return to the selected height. The new upper limit has now been set.

To set the lower-limit position

Use the 'DOWN' buttons to move the base to the desired minimum height position.

Press the 'M' button and release. Press the 'DOWN' button and release. The LED display will flash 'S'. Press and hold the 'M' button for about 2 seconds or until the LED display changes to '000'. The display will automatically return to the selected height. The new lower limit has now been set.

To remove the upper/lower limit position

Press and hold the 'M' button until the LED display flashes 'S' and then release it. Within roughly 5 seconds, press the 'M' button again and hold for 2 seconds. The LED display will change to '555' and then automatically return to the height display. The upper and lower limits are now removed.

3

To lock the handset

Press and hold the 'M' button (for roughly 8 seconds) until the LED display switches to 'S', then back to the height display. Keep holding the button until the handset changes to 'LOC'. Release the button.

To unlock the handset

Press and hold the 'M' button (about 8 seconds) until the LED display switches from 'LOC' to the height display. Release the button.

Programming

4 **Setting the LED retracted height**

Press the 'DOWN' button until the base reaches its lowest position.

Press the 'DOWN' button again until the LED flashes 'RST'.

Press and hold the 'M' button until the LED shows the current starting height.

Then use the UP/DOWN buttons to revise the starting height.

The display will automatically return to a flashing 'RST'.

Press the 'DOWN' button again until the base has lowered, then slightly risen.

The new retracted height has been set.

5 **Changing the pre-set program**

Follow the reset instructions until the Led flashes 'RST'

After this has happened, hold down the '1' button to switch the program.

Display will automatically return to a flashing 'RST'.

Press the 'DOWN' button until the base has lowered and then risen slightly.

The program has been set.

*10.1 is the One-touch program – meaning you can press the pre-set button and desk will go to required height that was pre-set.

*10.2 is the Constant-touch program – meaning you must hold down the button until desk goes to required height.

6 **Changing between inches / centimetres**

Press the 'DOWN' button until the base reaches its lowest position

Press the 'DOWN' button again for about 5 seconds, or until LED changes to a flashing 'RST'

Press the '2' button to switch the setting.

Programming

6

The display will automatically return to a flashing 'RST'.

Press the 'DOWN' button until the base has lowered a little and then slightly risen.

The new setting is displayed.

Repeat this process to switch back.

*10.3 is centimetres

*10.4 is Inches

7

Changing the anti-collision sensitivity

Press the 'DOWN' button on the handset until the base reaches its lowest position.

Press and hold the 'DOWN' button until LED display reads 'RST'.

Press and hold the 'UP' button for about 5 seconds while the LED flashes 'RST' and then switches to either:

10.5 – 10kg pressure (most sensitive)

10.6 – 15kg pressure (mid sensitivity)

10.7 – 20kg pressure (least sensitive)

Release the 'UP' button. Press and hold the 'UP' button again until the desired setting has reached.

Once the chosen setting is displayed, release the button and wait roughly 5 seconds for the display to return to 'RST'

Finish the reset process by pressing and holding the down button until the desk lowers a bit then rises and stops. Release the button. The new anti-collision sensitivity setting is saved, and your desk is now ready to use.

8

Setting the memory pre-set buttons

Press the 'M' button once and the display will change to 'S -'. Then select and press one of the Memory pre-set buttons. The position has been saved.

Using the Up/Down buttons, move the base to the next desired position and repeat process.



- Increase productivity
- Prolong life expectancy
- Improve circulation
- Burn fat

Standing just 15 min per hour provides great health benefits.



LEAP

TAKING HEALTH SERIOUSLY

The display will automatically return to a flashing 'RST'. Press the 'DOWN' button until the base has lowered a little and then slightly risen. The new setting is displayed.

Repeat this process to switch back.

*10.3 centimetres

*10.4 inches

Changing the anti-collision sensitivity

Press the 'DOWN' button on the handset until the base reaches its lowest position. Press and hold the 'DOWN' button until LED display reads 'RST'. Press and hold the 'UP' button for about 5 seconds while the LED flashes 'RST' and then switches to either:

10.5 – 10kg pressure (most sensitive)

10.6 – 15kg pressure (mid sensitivity)

10.7 – 20kg pressure (least sensitive)

Release the 'UP' button. Press and hold the 'UP' button again until the desired setting has reached.

Once the chosen setting is displayed, release the button and wait roughly 5 seconds for the display to return to 'RST'

Finish the reset process by pressing and holding the down button until the desk lowers a bit then rises and stops. Release the button. The new anti-collision sensitivity setting is saved, and your desk is now ready to use.

Setting the memory pre-set buttons

Press the 'M' button once and the display will change to 'S-'. Then select and press one of the Memory pre-set buttons. The position has been saved. Using the Up/Down buttons, move the base to the next desired position and repeat process.

4

Setting the LED retracted height

Press the 'DOWN' button until the base reaches its lowest position.

Press the 'DOWN' button again until the LED flashes 'RST'.

Press and hold the 'M' button until the LED shows the current starting height.

Then use the UP/DOWN buttons to revise the starting height.

The display will automatically return to a flashing 'RST'.

Press the 'DOWN' button again until the base has lowered, then slightly risen.

The new retracted height has been set.

5

Changing the pre-set program

Follow the reset instructions until the Led flashes 'RST'

After this has happened, hold down the '1' button to switch the program.

Display will automatically return to a flashing 'RST'.

Press the 'DOWN' button until the base has lowered and then risen slightly.

The program has been set.

*10.1 is the One-touch program – meaning you can press the pre-set button and desk will go to required height that was pre-set.

*10.2 is the Constant-touch program – meaning you must hold down the button until desk goes to required height.

6

Changing between inches / centimetres

Press the 'DOWN' button until the base reaches its lowest position

Press the 'DOWN' button again for about 5 seconds, or until LED changes to a flashing 'RST'

Press the '2' button to switch the setting.

1

Resetting the base

When the LED display shows an error code, press the 'DOWN' button for up to 5 seconds until the LED changes to a flashing 'RST'

Press the 'DOWN' button again until the base has lowered and then slightly risen. The base is now ready for use.

2

To set the upper-limit position

Use the 'UP' button to move the base to the desired max height position.

Press the 'M' button and release. Press the 'UP' button and release. The LED display will flash 'S'. Press and hold the 'M' button for about 2 seconds, or until the LED changes to '999'. The display will automatically return to the selected height. The new upper limit has now been set.

To set the lower-limit position

Use the 'DOWN' buttons to move the base to the desired minimum height position.

Press the 'M' button and release. Press the 'DOWN' button and release. The LED display will flash 'S'. Press and hold the 'M' button for about 2 seconds or until the LED display changes to '000'. The display will automatically return to the selected height. The new lower limit has now been set.

To remove the upper/limit position

Press and hold the 'M' button until the LED display flashes 'S' and then release it. Within roughly 5 seconds, press the 'M' button again and hold for 2 seconds. The LED display will change to '555' and then automatically return to the height display. The upper and lower limits are now removed.

3

To lock the handset

Press and hold the 'M' button (for roughly 8 seconds) until the LED display switches to 'S', then back to the height display. Keep holding the button until the handset changes to 'LOC'. Release the button.

To unlock the handset

Press and hold the 'M' button (about 8 seconds) until the LED display switches from 'LOC' to the height display. Release the button.

Trouble Shooting

If your desk is not functioning properly it may need to be reset. Follow the RESET procedure outlined in the USE section.

If your desk has a handset with an LED readout and it displays "RST" (reset), perform the reset procedure outlined in the USE section.

If the LED readout displays an error message (*Er1* - *Er13*) confirm that all wired connections are secure (legs to cables, cables to control box). Then perform the reset procedure outlined in the USE section.

If the error message persists after the reset procedure, contact your seller.

If the height between the legs exceeds 1.5 inches, stop the reset procedure & contact your seller.

If the handset displays "HOT", let the base cool down for 20 minutes.

Height Range	595 - 1245 mm (without desktop)
Base Width	1200 - 1800 mm
Travel Speed	40 mm per second (no load)
Distributed Load	125kg
Duty Cycle	After 2 min. continuous use rest for 18 min to prevent overheating Soft start/stop Adjustable leveling studs 3 Memory presets

RESET PROCEDURE

Press and hold the DOWN button on the Handset until the desk reaches its lowest height. Release the DOWN button. Press and hold the DOWN button again until the LED display reads "RST" or about 10 seconds on non-LED handset models. Release the DOWN button. Press and hold the DOWN button again until the desk lowers a little bit more, slightly rises and stops. Release the DOWN button. Your desk is now ready to use.

The desk base can be adjusted by pressing and holding either the UP or DOWN button until the desired height is reached.

To program up to three presets (on some models): Use the up/down buttons to find a desired height, then press "M" followed by a number 1 - 3.

CAUTION

Once a Preset button is pushed, the desk will move to the programmed height (see caution below).

Make sure no obstacles are in the desk's path. Make sure the desktop is not touching any walls. Make sure all cords are appropriate length to accommodate the change in height.

IMPORTANT: You must RESET the desk prior to use.

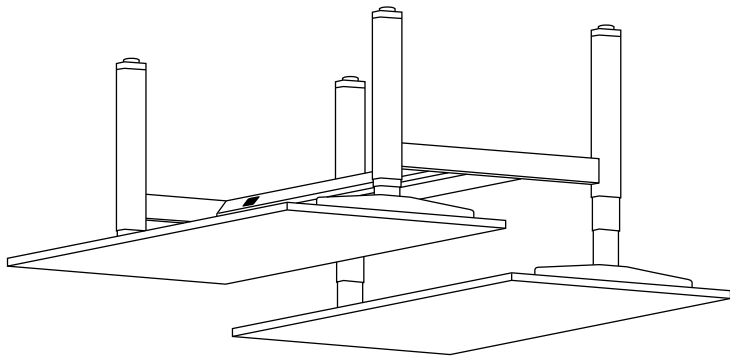

12

Plug the Power Cord (part 8) into a 230v outlet.

11

Turn the assembled desk right-side up. With at least two people, grab the DESK BASE (not the desktop) and turn the desk right-side up. Adjust the pre-installed glides on the Feet as needed.

10

Slide the Control Box (part 9) onto the Frame.
 Connect the cable exiting the Leg that is attached to the Frame directly into the Control Box (part 9).

Connect the Cable (part 21) to the other Leg and to the Control Box (part 9).

Connect the Handset (part 19) cable to the Control Box (part 9).

Connect the Power Cord (part 20) to the Control Box (part 9).

Use the adhesive-backed Cable Clips (part 22) to secure the cables so they do not sag.

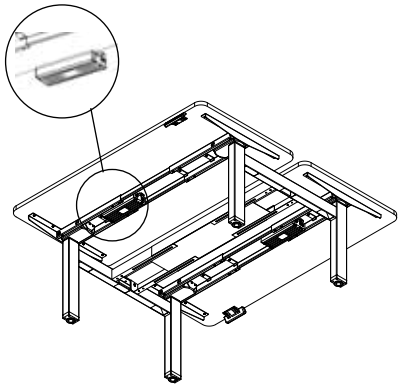

7

Use sixteen (16) M6*10 Machine Screws to fix the Centre Rails with Frames.

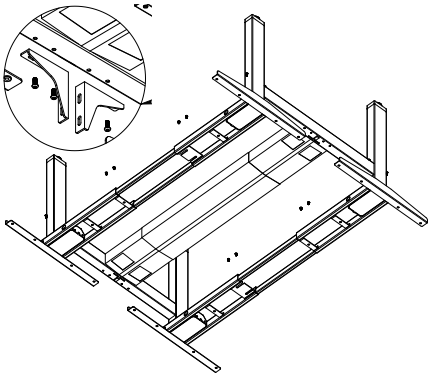

8

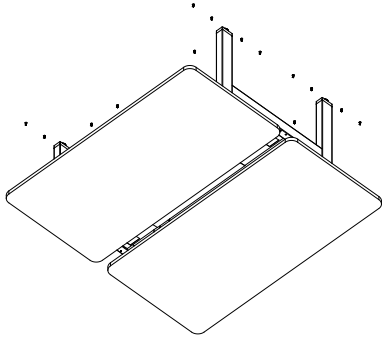

If using different drilled top attached the desk base to the underside of the desktop using twenty two (22) ST5 x 20 wood screws (Part 17). Please note you will have twenty two (22) M6 x 14 machine screws (part 15) spare. We recommend leaving 30mm gap between desktops.

OR

If using pre drilled top attach the desk base to the underside of the desktop using twenty two (22) M6 x 14 Machine screws (part 15). Please note you will have twenty two (22) ST5 x 20 Wood screws (part 17) spare.

6

Attach the Handset (part 19) so the front of the handset is flush with the front desktop edge (or recessed up to 1/8"). The handset may be placed anywhere along the front edge of the desktop but we recommend placing it toward an end so it does not interfere with your chair when seated. Use two (2) ST5x16 Wood Screws (part 18) to attach the handset to the desktop.



Do not overtighten screws in this step. Overtightening could cause damage to the components.

Please note you wont need extension cable (part 10) if using a small top.

To keep cables neat and tidy we recommend you purchase a cable basket.

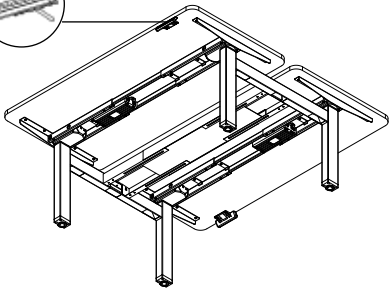

8

6

Use eight (8) M6*10 machine screws to fix the screenholder as picture shows

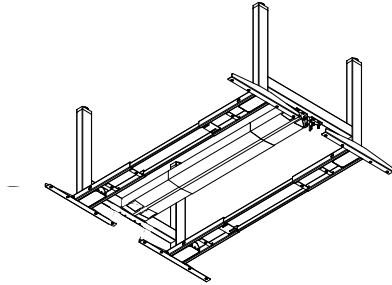

5

Use four (4) M6*10 Machine Screws to fix the cable tray as picture shows.

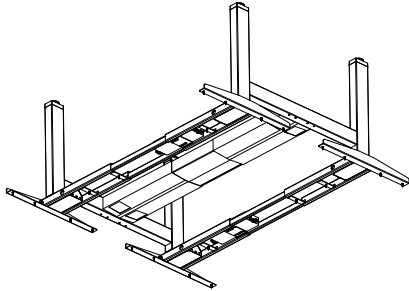

4

Slide the Side Brackets into the Frames. Use eight (8) M6*14 Machine Screws to fix the Side Brackets and Frames.

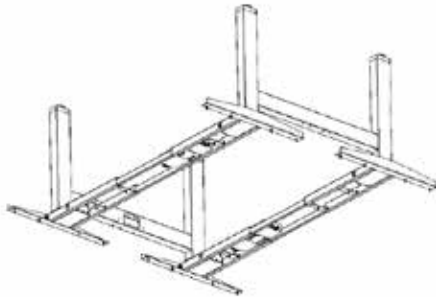

Make sure no obstacles are in the desk's path. Make sure the desktop is not touching any walls. Make sure all cords are appropriate length to accommodate the change in height.

IMPORTANT: You must RESET the desk prior to use.



1

Prepare the four (4) legs as the picture shows.

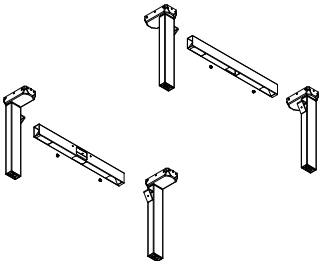

2

Using the supplied Allen Wrench, insert four (4) M8*12 Machine Screws to fix the beams and legs as the picture shows. Use the Sixteen (16) M6*14 Machine Screws to attach the feet.

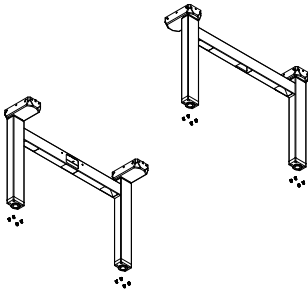

3

Use Sixteen (16) M6*10 Machine Screws to fix the Frames and Legs. Put the Centre Rails into Frames as the picture shows.

Slide the Centre Rails into the Frame Ends ensuring: a) the slots in the Centre Rail face inward b) the slots in the Centre Rail are closer to the top edge when the assembly is upside down.

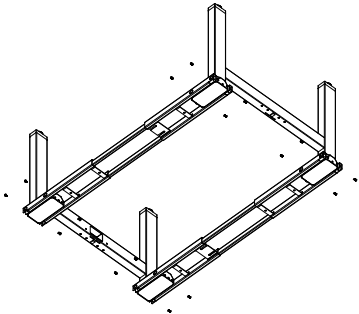

Parts List

Parts Diagram

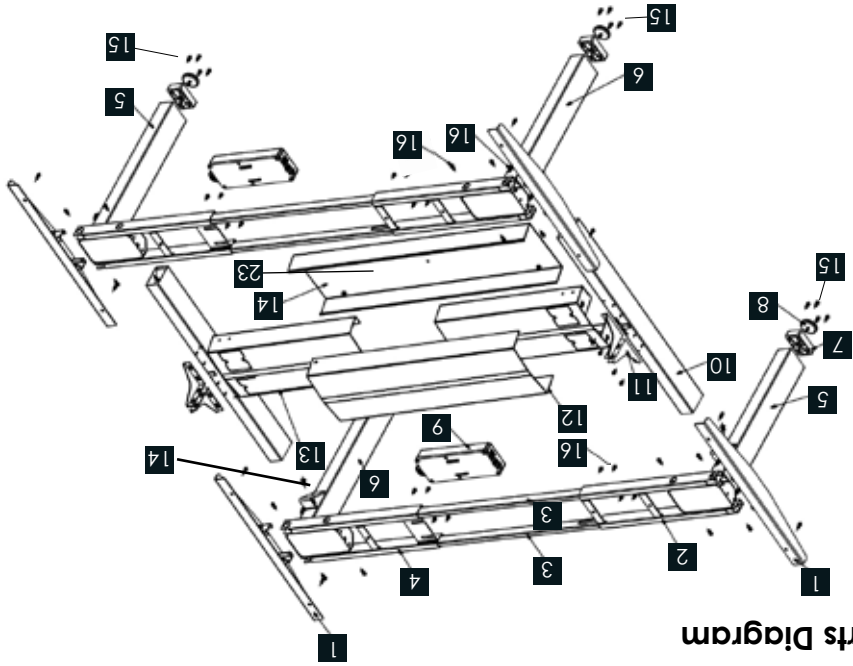

Part	Qty
1 Side Bracket	4
2 Frame 1	2
3 Center Rail	4
4 Frame 2	2
5 Leg (Right)	2
6 Leg (Left)	2
7 Foot	4
8 Glides	4

Part	Qty
9 Control Box	2
10 Beam	2
11 Screen Holder	4
12 Cable Tray Cover	1
13 Cable Tray	2
14 M8x12 Machine Screw	4
15 M6x14 Machine Screw	46
16 M6x10 Machine Screw	44

Part	Qty
17 ST5*20 Wood Screw	22
18 ST5*16 Wood Screw	4
19 Handset	2
20 Power Cord	2
21 Cable	2
22 Cable Clip	20
23 Bottom of Cable Tray	1

Parts List

Tools



4mm Allen Wrench (Included)



Phillips Head Screwdriver
and/or Power Drill



Tape Measure

1 x 4	2 x 2	3 x 4	4 x 2	5 x 2	6 x 2
7 x 4	8 x 4	9 x 2	10 x 2	11 x 4	12 x 1
13 x 2	14 x 4	15 x 24	16 x 44	17 x 22	18 x 4
19 x 2	20 x 2	21 x 2	22 x 20	23 x 1	24 x 2

Components

Assembly

Make sure no obstacles are in the desk's path.
 Make sure the desktop is not touching any walls.
 Make sure all cords are appropriate length to accommodate the change in height.



WARNING
 Pinch Point
 Keep hands and fingers clear.

Keep children away from electric height-adjustable desks, control units and handsets. There is a risk of injury and electric shock.



Keep all electrical components away from liquids.



Do not sit or stand on the desk frame.
 Do not crawl or lie under the desk frame.



Do not place any objects taller than 20" underneath the desk.



Do not open any of the components - the Legs, Control Box, or Switch.
 There is a danger of electric shock.



This product is designed with a duty cycle of 10%
 (2 min. on, 18 min. off).



In the event of a power outage or if the power cord is unplugged, a manual reset may be necessary - see USE section.



IMPORTANT: You must RESET the desk prior to use.



Use / Liability

This height adjustable desk has electric motors and is designed for use in dry work areas only.
 The desk height is adjustable so that it can be positioned at the most ergonomically suitable height.
 Any other use is at users risk.

Under no circumstances does the manufacturer accept warranty claims or liability claims for damages caused from improper use or handling of the desk frame.
 Please be informed that the anti-collision software is designed for furniture protection, not human protection.

Contents

Bench

Use/Liability	3
Parts List/Tools	4-5
Assembly	6-10
Trouble Shooting	11
Specifications	11
Programming	12-14

Please see reverse of booklet for single instructions

Standing Desks

with

Office Wellbeing

a stand for

Take

Bench Assembly & User Instructions

